

**SOUTH APRON PLAN**

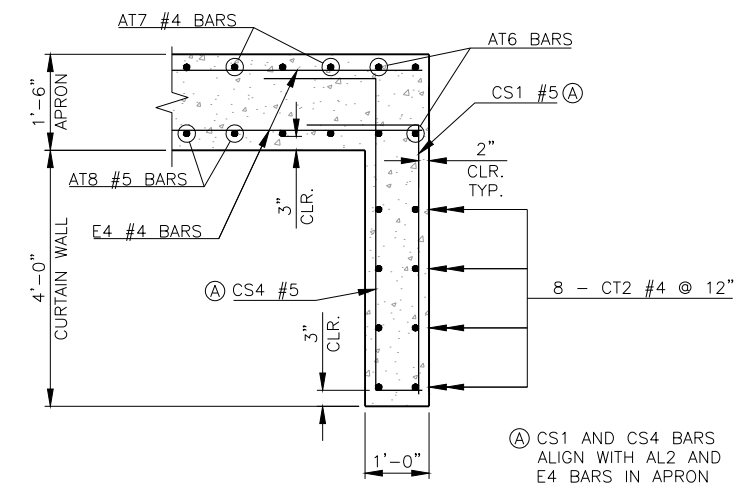

**SOUTH CURTAIN WALL SECTION**

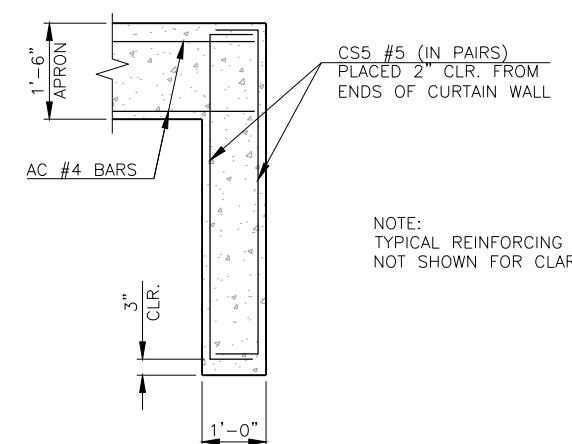

**SOUTH CURTAIN WALL END SECTION**

NOTE:  
TYPICAL REINFORCING  
NOT SHOWN FOR CLARITY.

**SOUTH APRON AND CURTAIN WALL BAR LIST**

PLAIN REINFORCING					
MARK	SIZE	NO.	FORM	LENGTH	LENGTH VARIATION
AC	#4	4	BNT.	3'-8"	
AD2	#4	4	STR.	33'-6"	
AL2	#4	60	STR.	14'-8" AVG.	2'-6" TO 26'-10"
AT4	#4	1	STR.	22'-6"	
AT5	#5	1	STR.	22'-6"	
AT6	#4	4	STR.	53'-6"	
AT7	#4	27	STR.	38'-1" AVG.	23'-1" TO 53'-1"
AT8	#5	27	STR.	38'-1" AVG.	23'-1" TO 53'-1"
CS1	#5	56	BNT.	5'-9"	
CS4	#5	56	BNT.	7'-5"	
CS5	#5	4	BNT.	6'-4"	
CT2	#4	8	STR.	53'-6"	

① 4 SETS OF 15 BARS

NOTE:  
FOR AC AND CS1 BAR BENDS, SEE SHEET B017.

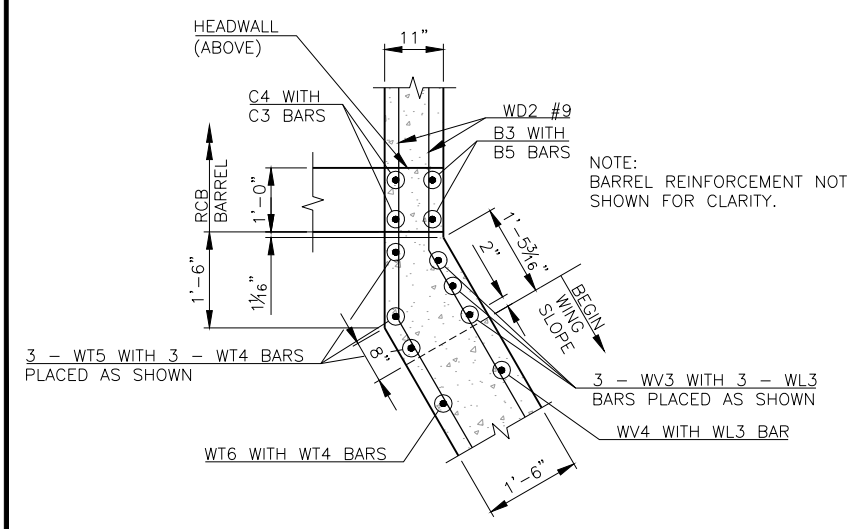
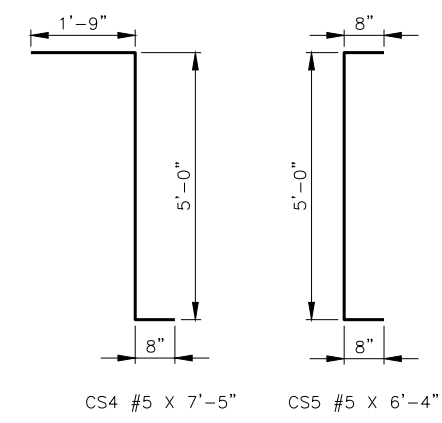

**SECTION OF WING AT BARREL**

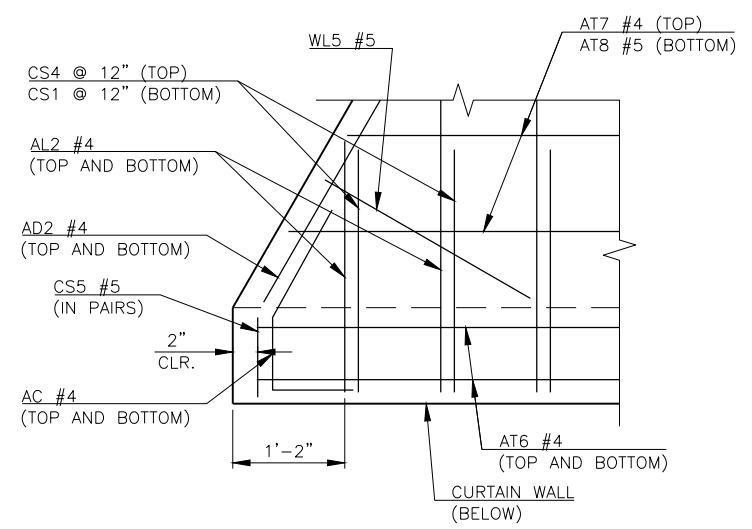

**DETAIL "A"**